

Understanding Line Leak Detection Systems

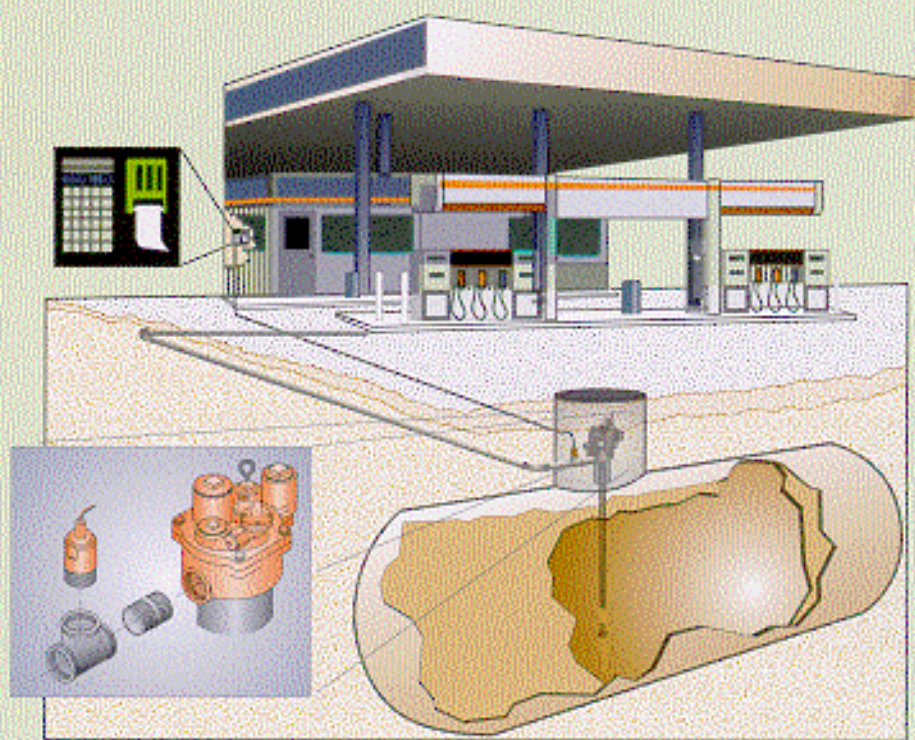

June 2000

State Water Resources Control Board

California Environmental Protection Agency

This booklet contains information about line leak detectors (LLDs). Although the booklet is intended primarily to assist local agency inspectors, tank owners and operators, consultants, and contractors may also find this information useful. It will discuss the technological principles of LLDs and provide an overview of installation, inspection, maintenance, and special features of these devices. In addition to technical information, this booklet will also provide regulatory information.

The regulatory requirements referred to in this booklet are in the California Code of Regulations Title 23, Division 3, Chapter 16. To obtain a copy of these regulations or additional copies of this booklet, please fax your request to the State Water Resources Control Board, Underground Storage Tank Program, at **(916) 227- 4349**, call **(916) 227- 4303**, or visit our website at **<http://www.swrcb.ca.gov/cwphome/ust>**

Any reference to or depiction of commercial products is solely for explanatory purposes and is not intended as an endorsement.

This document was prepared by the following SWRCB staff:

Shahla Dargahi Farahnak, P.E., Senior Water Resources Control Engineer
Mary Drewry, Water Resources Control Engineer
Scott Bacon, Engineering Student Assistant

We would like to thank the following for their contributions in reviewing this document.

Julie Berrey, SWRCB

Greg Breshears, County of Santa Clara Environmental Resources Agency

Laura Chaddock, SWRCB

Robert Hart, Veeder-Root

David Holtry, SWRCB

Curt D. Johnson, Alabama Department of Environmental Management

John Kneece, S. Carolina Department of Health & Environmental Control

Marcel Moreau, Marcel Moreau Associates

Charles Northrop, Charles Northrop and Associates

Edward Olson, Minnesota Pollution Control Agency

Jeff Tobin, State of Montana Department of Environmental Quality

John Welch, SWRCB

John White, City of Anaheim Environmental Protection Section

Barbara Wightman, SWRCB

TABLE OF CONTENTS

INTRODUCTION	1
PART I - OVERVIEW OF PIPING SYSTEMS	3
1.1 Overview of Piping Systems	5
1.2 Delivery Methods	5
1.3 Construction Material	6
1.4 Single-Walled and Double-Walled Piping	7
PART II - MECHANICAL LINE LEAK DETECTORS	9
2.1 Introduction to Mechanical Line Leak Detector	11
2.2 Equipment Components	12
2.3 Leak Detection Mechanism	14
2.4 Interference to the Leak Detection Mechanism	17
2.5 Installation Overview	21
2.6 Maintenance of the MLLD	22
2.7 Inspection of the MLLD	22
PART III - ELECTRONIC LINE LEAK DETECTORS	23
3.1 Introduction to Electronic Line Leak Detector	25
3.2 Equipment Components	26
3.3 ELLDs and Automatic Tank Gauging System	27
3.4 Leak Detection Mechanism	28
3.4.1 Pressure Decay ELLDs	28
3.4.2 Volume Displacement ELLDs	28
3.4.3 Constant Pressure ELLDs	29
3.5 Wireless ELLD Systems	30
3.6 Interference to the Leak Detection Mechanism	30
3.7 Installation Overview	34
3.8 Maintenance of the ELLD	35
3.9 Inspection of the ELLD	36
APPENDIX A - INSPECTION AND MAINTENANCE CHECKLISTS	A-1
Mechanical Line Leak Detector Inspection Checklist	A-2
Electronic Line Leak Detector Inspection Checklist	A-3
Line Leak Detector (LLD) System Certification	A-4
APPENDIX B - REGULATORY REQUIREMENTS	B-1
Monitoring Requirements for Single-Walled Piping Systems	B-2
Monitoring Requirements for Double-Walled Piping Systems	B-3
APPENDIX C - THIRD PARTY CERTIFICATION OF LINE LEAK DETECTORS	C-1
Third-Party Certification	C-2
Conducting the Evaluation	C-3
Leak Detection Equipment List	C-4
APPENDIX D - REFERENCES	D-1
References	D-2

INTRODUCTION

Underground storage tank (UST) systems are composed of tanks, associated piping, and pumps that deliver product to dispensers (see Figure 1). Monitoring these systems for leaks is required by state and federal laws and is intended to help detect a release before groundwater is contaminated. Line leak detectors (LLDs) are devices that alert the tank operator to the presence of a leak in underground piping by restricting or shutting off the flow of product through the piping, or by triggering an audible or visual alarm. They are installed in the product line, usually in or near the pump head.

LLDs are divided into two categories: Mechanical Line Leak Detectors (MLLD) and Electronic Line Leak Detectors (ELLD). Mechanical line leak detectors are designed to perform frequent testing of the piping to detect catastrophic leaks (3 gph or higher). Electronic line leak detectors also test for catastrophic leaks, but they can perform more sensitive leak tests (0.1 gph and 0.2 gph) as well. These more sensitive tests are designed to detect small leaks, which become a major problem if not detected and repaired. Both MLLDs and ELLDs are available in a wide assortment of models, representing a variety of leak detection mechanisms and features.

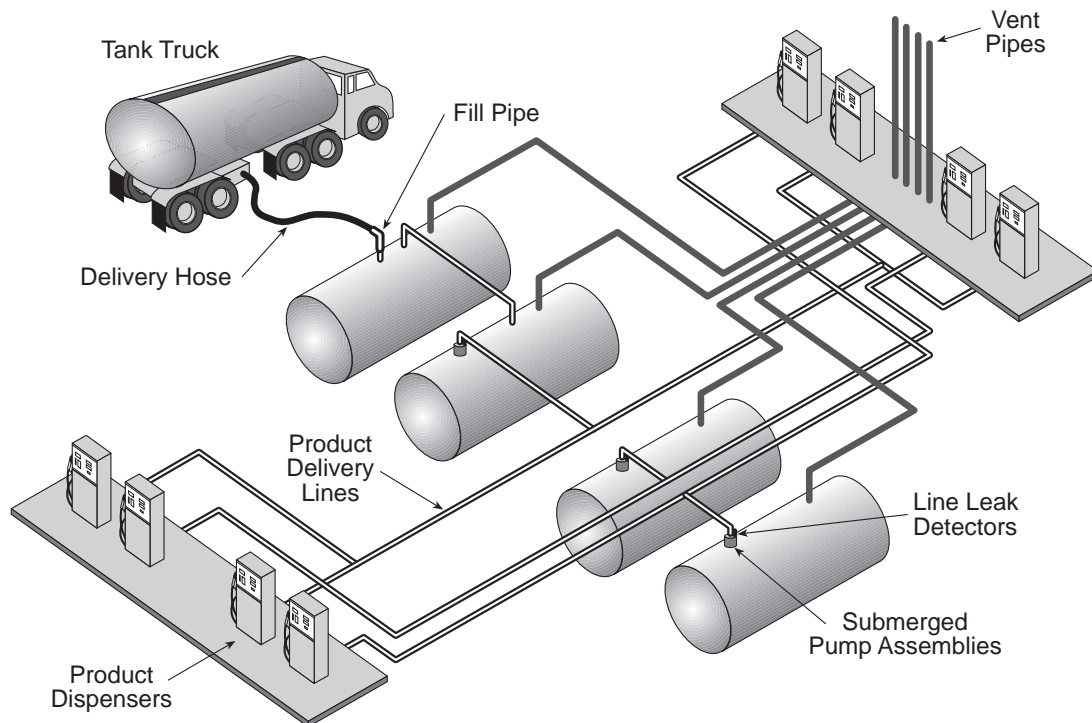

Figure 1 - A Typical Retail Service Station with Pressurized Piping System

PART I

Overview of Piping Systems

1.1 Overview of Piping Systems

In order to understand the operation of LLDs, it is necessary to have a basic knowledge of different types of piping systems. There are various piping systems commonly in use today and each is subject to specific monitoring requirements (see Appendix B). Piping systems can be categorized by three main properties: delivery method, construction material, and levels of containment.

1.2 Delivery Methods

Delivery method is the way in which product is moved through the piping. There are three common delivery methods in use: suction, pressurized, and gravity. Each method has specific characteristics and leak detection considerations. Line leak detectors are only designed for use with pressurized delivery lines, so this text will be limited to discussion of pressurized systems.

- Suction piping systems use a pump located above grade, which *pulls product* to the dispenser. At gas stations, the pumping unit is located in the dispenser. Suction systems in which there is no pump or valve installed below grade and where the piping slopes back into the storage tank are known as **safe suction** systems. If these conditions are not met, it is known as a **conventional suction** system.
- Pressurized piping systems use a submersible pump to deliver product from the tank to the dispenser.
- Gravity piping systems have no pump, and rely on the downward slope of the piping to transport product.

Pressurized Piping

Pressurized pipelines transport product by pushing it through piping using a submersible pump. The pump head is located above the tank (see Figure 2), in a sump that is typically accessible by a manhole. The pump turbine is located directly below the pump head in the bottom of the tank. Pressure in the line is typically 28 - 30 psi, depending upon the horsepower of the pump. A single pump can supply product to several dispensers simulta-

neously. Factors such as the volume of product dispensed, desired delivery time, and the layout of the UST facility will determine the configuration of system. Pressurized systems are generally chosen for high-volume facilities with multiple dispensers because the product can be delivered to several dispensers efficiently and quickly.

Large releases of product can occur quickly in leaking pressurized lines. The pump will continue to push product through a leaking line if it is not shut down immediately.

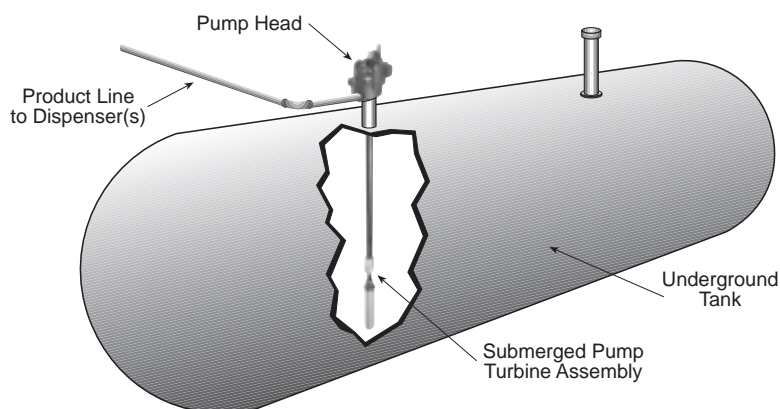

Figure 2 - Submersible Pump Location

1.3 Construction Material

UST system piping comes in three main varieties of material: steel, fiberglass-reinforced plastic (FRP), and flexible. When properly installed and maintained, each material can work reliably. The choice of material will depend on specific UST facility factors such as stored product, installation cost, long-term reliability, and contractor experience.

Always make sure the piping material, piping connections, and any sealants or adhesives used are compatible with the substance stored.

Steel is the least common material in newer UST piping. It is strong and durable but expensive to install. Steel piping is generally found in specialty systems where the chemicals stored would be incompatible with other piping materials, or in older upgraded facilities where corrosion protection has been added to meet California's regulations.

FRP is the most common piping material in use today. It has been the industry standard for many years. FRP is strong, durable, and corrosion resistant. Since FRP piping is bonded in the field and constructed such that there are many connections in the piping, leaks will most likely occur at connections where two or more sections of piping are bonded together.

Flexible piping is a technology developed in the early 1990's. It is often less expensive than FRP or steel piping since it is less labor intensive to install. Flexible piping uses fewer leak-prone connections than the other materials since it can be rolled off a spool to the required length and swept around corners rather than using piping unions and angled fittings. The long-term durability of flexible piping is less proven than that of the other materials, as its use has only recently become common.

Line Leak Detectors must be certified for use with the piping material of the line they are monitoring.

1.4 Single-Walled and Double-Walled Piping

Piping can be constructed in single-walled or double-walled form. Older UST systems will typically have single-walled piping, as this was the industry standard for many years. Any leaks from single-walled piping will release product directly into the surrounding environment.

See Appendix B for details on regulatory requirements for monitoring of single-walled and double-walled piping.

Double-walled piping is a pipe within a larger pipe (see Figures 3 and 4). This configuration provides an extra barrier between the product flowing through the inner pipe and the environment surrounding the outer pipe. The space between the inner and outer pipes is known as the interstitial space, and must be kept clean and dry. Double-walled piping must be installed with a slope, which causes any product in the interstitial space to drain to a collection point, known as a sump.

Liquid activated sensors are available to continuously monitor the sumps. They can trigger an alarm and shut off the pump if product is detected. This interstitial monitoring may be used in conjunction with LLDs (see Appendix B).

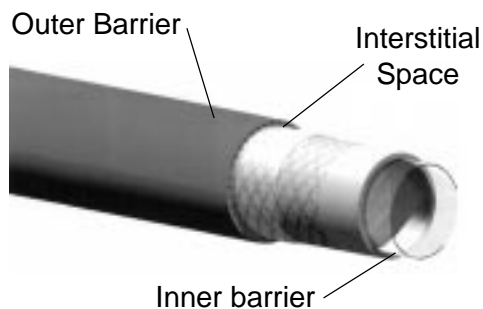

Figure 3 - Example of Flexible Double-Walled Piping



Figure 4 - Example of FRP Double-Walled Piping

PART II

Mechanical Line Leak Detectors

2.1 INTRODUCTION TO MECHANICAL LINE LEAK DETECTORS

Mechanical Line Leak Detectors (MLLDs) are pressure-operated valves designed to detect leaks of 3 or more gallons per hour (gph). Typically, they are installed on the head of the submersible pump located in a sump (see Figure 5). MLLDs perform a test of the piping each time the pump is turned on. In the event of a failed leak test, MLLDs are usually only capable of reducing the flow of product to the dispenser, not stopping it completely. However, there are some models available that use a mechanical detector along with an electronic relay to shut down the pump when the MLLD detects a potential leak.

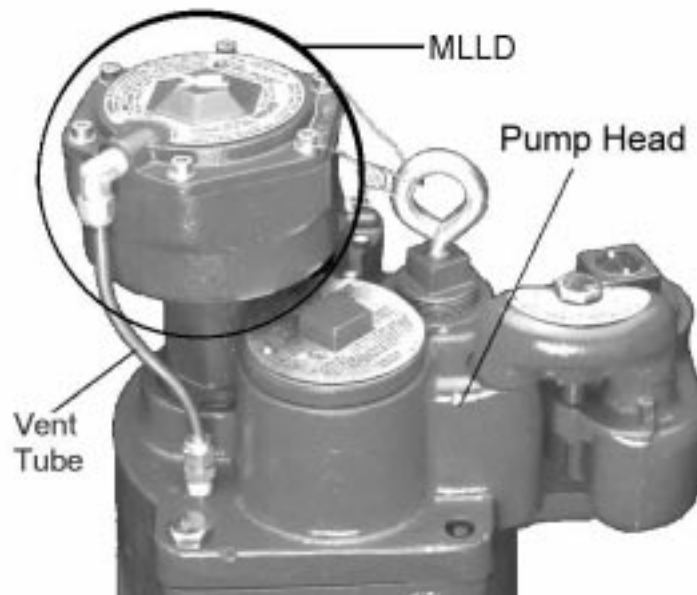

Figure 5 - MLLD Installed in Submersible Pump

MLLDs are constructed with one of two operative mechanisms, diaphragm or piston. Both types are pressure operated valves installed on the head of the submersible pump, or with a specialized “T” fitting at the pump outlet. Both types operate similarly, although each uses a different kind of moving part.

2.2 EQUIPMENT COMPONENTS

Diaphragm MLLDs - pressure in the piping pushes against a diaphragm made of synthetic material (see Figure 6). Generally, diaphragm MLLDs are used in low-volume product lines.

Piston MLLDs - are equipped with a piston that moves up and down, responding to changes of pressure in the product line (see Figure 7). Generally, the piston MLLDs are used on high volume product lines, such as those found at service stations.

Both types of MLLDs monitor leaks using the following components (see Figures 6 and 7):

- **Metering Pin/Poppet** - The device that regulates flow of product into the delivery pipeline. The metering pin and poppet are precisely calibrated to regulate flow between 1.5 and 3 gph at 10 psi.
- **Stem or Piston Rod** - This metal conduit connects the poppet to the piston or diaphragm. In piston MLLDs it is known as a piston rod, and in diaphragm MLLDs it is known as a stem. Its function is to allow the product to flow through the MLLD to the piston or diaphragm. The product then applies pressure to the piston or diaphragm, which moves the poppet.
- **Pressure Relief Valve & Vent (piston type only)** - The pressure relief valve prevents the build up of pressure that could damage the MLLD. In the event of excessive pressure build up or a failed piston seal, the product will vent past the relief valve and back into the tank through a copper vent line.
- **Spring** - The spring controls the movement of the MLLD components through the various stages of testing. It resists pressure in the line and closes the valve when pressure is low.

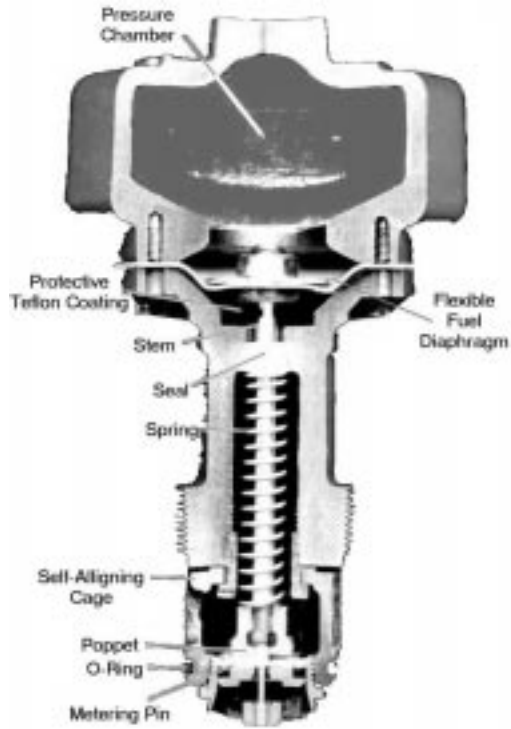

Figure 6 - Example of a Diaphragm MLLD

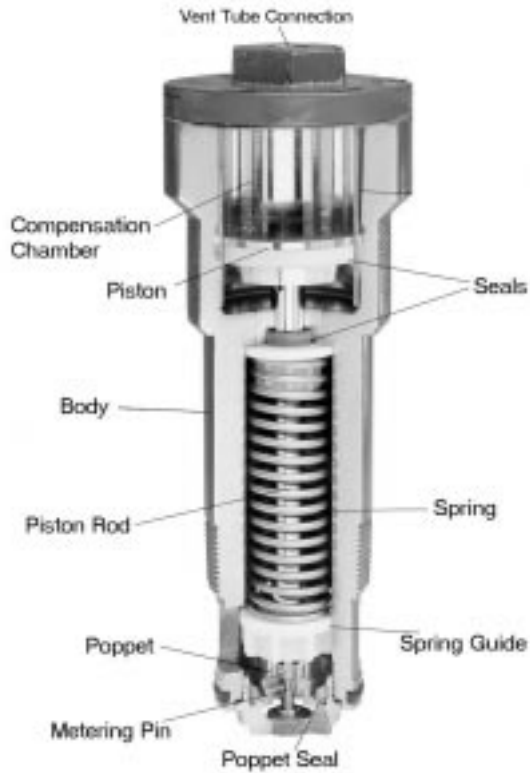

Figure 7 - Example of a Piston Type MLLD

2.3 LEAK DETECTION MECHANISM

The MLLD monitors pressure each time the pump is turned on to dispense product. It allows only a small amount of product to flow into the pipeline, which should build pressure. If there is no pressure build-up, it is interpreted as a potential leak in the line and the metering pin restricts product flow. If pressure does increase as expected, the MLLD permits full flow. There are three stages in the leak detection cycle of the MLLD, as described below (see Figures 8-10).

1. "Idle" Stage - While the dispenser and the pump are turned off, after completion of dispensing product from the nozzle, the system remains idle and product remains in the lines. If line pressure drops below a preset level (around 1 psi depending upon the specific MLLD model), the MLLD spring pushes the poppet downward into the "idle" (also known as "tripped") position. During this stage the poppet restricts product flow past the metering pin to approximately 1.5 to 3 gallons per minute. The next time a customer dispenses product, the pump will activate and product will flow into the line at this restricted rate. Pressure will quickly build in the line. This increased pressure pushes the piston or diaphragm upward slightly and moves the MLLD to the next stage.

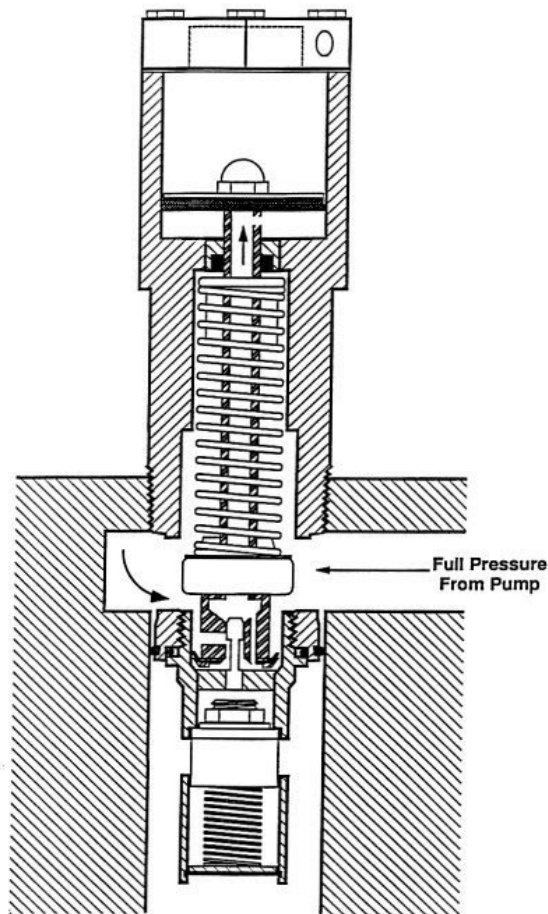

Figure 8 - Idle Stage

2. Slow Flow or Leak Detection Stage - During this stage the poppet moves into the leak detection mode, in which only a small flow is allowed to pass the metering pin, (3 gph or less). If there are no leaks, the pressure in the piping will begin to build quickly due to the product flowing past the metering pin. If pressure does not build, a catastrophic leak in the piping is suspected. In this event, product flow will remain between 1.5 and 3 gallons per minute. Customers frustrated by the slow product flow will alert a tank operator to this condition, and corrective action should be taken as warranted. If the line is free of catastrophic leaks, the increasing line pressure will push the piston or diaphragm upward into the "full flow" stage. The line pressure must build to approximately 20 - 22 psi for the piston type device, or 8 - 10 psi for the diaphragm type device in order to reach the full flow position.

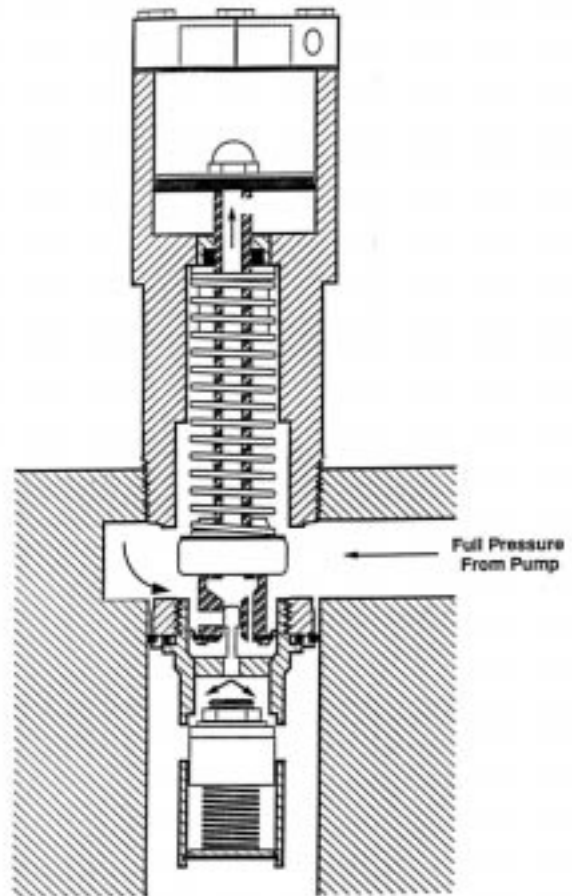

Figure 9 - Leak Detection Stage

3. "Full Flow" Stage - Full flow from the dispenser's nozzle indicates complete pressure build up and no large leak. In this case the poppet has moved into a position to allow full flow. The complete cycle (from the time the dispenser is turned on until the maximum flow is delivered) should take approximately three seconds. Once the dispenser is turned off the pressure in the pipeline will drop to the holding pressure of the relief valve in the pipeline. If there is a substantial pressure drop (due to a leak, thermal contraction, a leaking check valve, or for any other reason), the spring will push the poppet downward, forcing the MLLD back to the idle position to conduct another test.

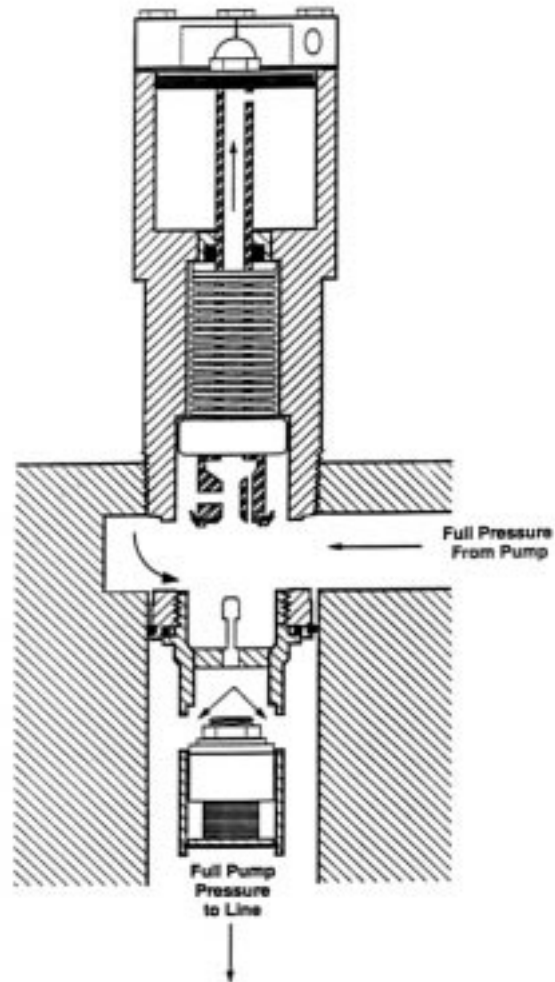

Figure 10 - Full Flow Stage

2.4 INTERFERENCE TO THE LEAK DETECTION MECHANISM

MLLDs, like most mechanical devices, are vulnerable to circumstances that may limit their effectiveness. The following tables describe some possible interferences to the proper operation of an MLLD, and how they can be corrected.

Continuous Pump Run

Problem	Solution
<p>If the submersible pump is allowed to run continuously, the MLLD will not return to the idle position and the system will be unable to enter the leak detection stage. In this situation the MLLD will never perform a line leak test.</p>	<p>MLLDs are not appropriate for use with continually running pumps. The situation that is causing continuous pump run (usually a dispenser left in the “on” position) must be corrected.</p>

Leaking Check Valve

Problem	Solution
<p>This occurs when there are leaks in the check valve or pressure relief valve installed in the product line, upstream of the MLLD. Each time the pump is turned off, the leaking valve allows the product in the line to drain back to the tank. With the line pressure so low, the MLLD will trip and it will take a long time for the entire line to fill at the reduced flow rate. This situation will create a noticeably longer cycle time and will shorten the service life of the MLLD due to excessive wear on the system’s functional parts such as the O-rings, piston, and diaphragm. While a leaking check valve may not release product into the environment, it is a great nuisance to customers and owners.</p>	<p>Check valves should be inspected and cleaned as indicated by the manufacturer. Leaking check valves should be replaced to avoid excessive MLLD wear and customer inconvenience.</p>

Trapped Vapor

Problem	Solution
<p>Air can be introduced to the system when the MLLD or other devices are being installed, maintained or replaced. This is generally referred to as trapped vapor or a vapor pocket. In order for the pump to pressurize the product lines, the vapor in the piping must be compressed. It will take more time to build up to the normal designed pressure of the MLLD if there is excessive vapor in the system (more vapor present means more time to build pressure). As a result of the time delay in attaining full flow, a possible leak is falsely suspected.</p>	<p>Excessive vapor pockets must be manually removed from the system. Since vapor will travel along with product, the most efficient way to remove the vapor is to dispense product. To accomplish this, the pipeline must be filled with product being delivered at a fast rate. Begin by starting the pump. Dispense product from the nozzle located farthest from the pump and work back towards the pump. All branches of the pipeline must be flushed. This approach will not work if the vapor is trapped in any piping stubs that product does not flow through. In these cases the stubs must be manually located and the vapor removed by the use of some type of air relief valve. It is best to eliminate this type of piping situation.</p>

Tampering

Problem	Solution
<p>MLLDs are precisely calibrated devices and are generally not to be serviced internally. Opening the MLLD, modifying it, or removing it from the system constitutes tampering, and will inhibit the MLLD's effectiveness in detecting leaks.</p>	<p>Most MLLDs are equipped with some type of tamper-evident seal. This seal should be checked periodically to ensure that tampering has not occurred. Seals may not be present on all MLLDs, so it is important to conduct the required annual testing to ensure proper operation. Defective MLLDs must be inspected by a qualified service professional and replaced.</p>

Thermal Contraction

Problem	Solution
<p>Thermal contraction can occur when product in a system cools. This is common when warm product is delivered into the system, or with long periods of idle time overnight. If the temperature of the product decreases as it moves from the tank into the pipeline, the volume that the product occupies also decreases. The result of the product contracting is lower pressure in the pipeline, which to the LLD is the same as a leak. This occurs even though no product has left the pipeline. Thermal contraction most often occurs in the mountains and desert areas where there is a significant change in daytime highs and nighttime lows. Slow station activity compounds the problem, as product is allowed to sit in the lines and contract for extended time periods.</p>	<p>Piston type MLLDs with large compensation chambers (refer back to Figure 7) are less likely to be affected by thermal contraction. The amount of product in the compensation chamber can compensate for the perceived product loss due to thermal contraction.</p>

Thermal Expansion

Problem	Solution
<p>Thermal expansion is the opposite of thermal contraction. When product stands in a line and is exposed to heat, it will expand. This causes the same quantity of product to occupy a greater volume. MLLDs could be affected by this increase in volume, since expanding product may mask a leak by maintaining line pressure in spite of a leak being present. As with thermal contraction, mountain and desert locations with widely varying temperature extremes are most likely to experience thermal expansion.</p>	<p>After September 22, 1991, EPA required LLD manufacturers to address the problem of thermal expansion and to design LLDs that compensate for approximately 25°F product to ground temperature difference. Manufacturers address this issue when designing their products, and most modern third-party certified LLDs are rarely affected by thermal expansion. See the manufacturer’s operations manual for specific instruction on identifying and alleviating thermal expansion.</p>

Static Head Pressure

Problem	Solution
<p>Static Head Pressure is the pressure exerted on the MLLD by the product contained in the line. The MLLD is usually installed several feet below the level of the dispenser. Product in the line above the MLLD will exert static head pressure of roughly 1.0 psi for every 3 vertical feet (as shown in Figure 11). This pressure pushes up on the piston or diaphragm and prevents the MLLD from going into the idle stage after pipeline activity. Each MLLD is designed to operate with a limited static head pressure, which varies depending on the make and model. The MLLD may not function properly if this limit is exceeded.</p>	<p>This problem can be solved by replacing the MLLD with one rated for use with a greater static head pressure. The MLLD may also be raised, decreasing the static head. Installing a longer riser pipe between the pump and tank will accomplish this. Check manufacturer's specifications to determine if this is an option with the specific MLLD in use.</p>

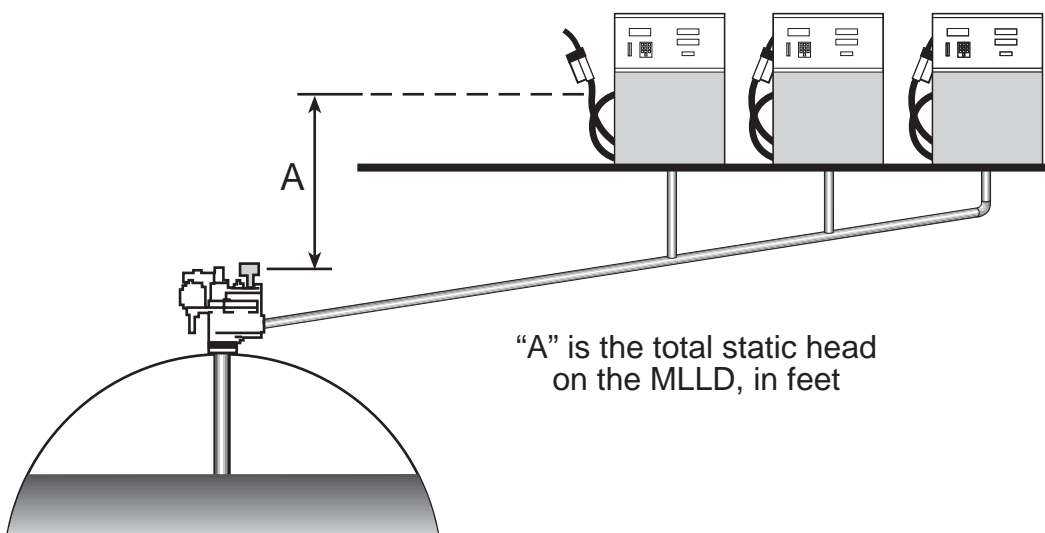

Figure 11 - Static Head Pressure

2.5 INSTALLATION OVERVIEW

The installation of the MLLD consists of installing the detector in the port of the submersible pump head and testing the unit to confirm that it is functioning properly and capable of detecting a simulated leak. Other general installation considerations and precautions are as follows:

- The pump is controlled by the dispenser and must be disconnected before installation can begin.
- The MLLDs are sensitive to static head pressure (refer back to Figure 11) and this must be addressed at the time of installation. If the pressure is too great (exceeding manufacturer's specifications) the detector will not perform correctly. If the MLLD is too sensitive to the static head pressure, use a riser pipe or install a different model MLLD.
- Use the procedure indicated by the manufacturer to connect the detector (for example, examine machined port in the pump head for signs of corrosion, apply thread sealant, and lubricate the "O" ring).
- After the installation is complete, power can be reconnected.
- Air must be purged from the pipelines and all threaded joints must be inspected for leaks before the system can be tested to ensure its detection capability.
- Follow the manufacturer's recommended procedure for the initial testing of the MLLD.
- If there is an apparatus designed to discourage tampering, install it now. The top cover can be secured with sealing wire and epoxy. This can be done by wrapping the sealing wire through the lifting lug and securing the wire to the cover with epoxy. The wire can also be wrapped around the screw on the cover and then secured to the submersible pump with epoxy. Any attempt to tamper with the MLLD will result in the breaking of the wire. Another method is to coat the screw on top of the MLLD with epoxy. Using this method, the epoxy will crack if the MLLD is tampered with.

If not installed in the pump head, the MLLD should be installed as close as possible to the submersible pump. This is because MLLDs will not respond to a leak in piping upstream from their location.

2.6 MAINTENANCE OF THE MLLD

To assist inspectors and tank owners with their review of annual operational check and maintenance records, a Line Leak Detector System Certification form is provided in Appendix A. The checklist was compiled based on a review of manufacturer requirements and contains a list of minimum procedures service personnel should perform during the annual certification. Service personnel must always follow manufacturer's instructions to perform maintenance and any specific calibration procedures. A copy of the checklist should be provided to the tank owner.

MLLDs must be quantitatively tested in accordance with manufacturer's instructions annually to verify that they respond to a 3.0 gph leak.

California Code of Regulations Title 23 Division 3, Chapter 16, requires annual certification of LLDs.

2.7 INSPECTION OF THE MLLD

The compliance inspection by the local agency staff should, at a minimum, include the following:

- Verify that the MLLD is third-party certified and listed in the current version of California's List of Leak Detection Equipment and Methods for Underground Storage Tanks.*
- Verify that the UST piping volume does not exceed the maximum volume listed in California's List of Leak Detection Equipment and Methods for Underground Storage Tanks for the MLLD in use.
- Verify that the MLLD is third-party certified for the piping material present (flexible, steel, or FRP).
- Confirm that the equipment installed at the facility is the equipment specified in the written monitoring program.
- Check the operator's knowledge and familiarity with the system.
- Verify that the operator is familiar with the proper responses to MLLD leak indication or slow-flow.
- Check if equipment manuals are available (preferably on-site).
- Review annual equipment certification reports.

A mechanical line leak detector inspection checklist is provided in Appendix A. This checklist may be used by inspectors to verify compliance or by tank owners/operators to perform a self-audit.

* This document is referred to as LG-113 and is on the SWRCB website at <http://www.swrcb.ca.gov/cwphome/ust> (See Appendix C for further information.)

PART III

Electronic Line Leak Detectors

3.1 INTRODUCTION TO ELECTRONIC LINE LEAK DETECTORS

Electronic line leak detectors (ELLDs) represent a significant technological advancement over Mechanical Line Leak Detectors. ELLDs usually incorporate a microprocessor, enabling a wider variety of test options. They also feature precisely calibrated sensors that allow for more sensitive tests on the piping. An ELLD is composed of a detection element that feeds data to a control panel. This panel interprets the data collected by the detection element and communicates the results to a tank operator by means of digitized display and/or text printout. The control panel can trigger audible and visible alarms and even shut off a pump in the event of a failed leak test. Additionally, the control panel allows a tank operator to program periodic line leak tests or to conduct a test whenever the lines have been inactive for extended periods.

ELLDs are designed to detect large leaks of 3.0 gph or higher as well as smaller leaks of 0.1 gph and 0.2 gph. The 3.0 gph leak test is a standard feature of these devices, and is performed after each dispensing event. The 0.1 gph and 0.2 gph tests are common optional features that may be set to be performed with each dispensing activity (given adequate quiet time), or at pre-scheduled times, such as opening or closing of the facility, monthly, or on demand. In addition, the ELLDs are capable of performing a diagnostic self-test or in some cases can simulate a leak to confirm proper operation. An ELLD may be connected to its own control panel, or to a panel that controls several ELLDs at the facility. Most ELLDs can also be connected to an automatic tank gauge control panel (a box that monitors and controls the tank liquid level probes and external sensors as well as the ELLDs).

There are several advantages of ELLDs as compared to MLLDs:

- Many ELLDs are capable of satisfying current requirements for monthly or yearly piping integrity tests. This feature can save a tank operator from the costs of line tightness testing.
- Many ELLDs can completely shut off the product flow by switching off power to the pump when the leak rate exceeds the designated threshold.
- ELLDs continually monitor their own operational status, and can be programmed to shut off product flow if the sensor/transducer has been disconnected or if the unit is not functioning properly.

As of December 22, 1998, all LLDs installed on single-walled pressurized lines in California must automatically shut off the pump if any of the following occur:

- *product loss exceeds the designed threshold of the LLD*
- *the detector malfunctions and/or fails a diagnostic test*
- *the detector is disconnected or disabled*

These requirements can only be satisfied through use of an ELLD.

3.2 EQUIPMENT COMPONENTS

Although various models and types of ELLDs have individual characteristics and components, they usually share similar fundamental features. Generally, ELLDs are composed of two main components as discussed in the following paragraphs.

Detection Element

The detection element is a sensor/transducer that measures either flow rate or change of pressure in the pipeline. It is usually installed in the leak detection port on a submersible pump where the MLLD would be. Typically a microprocessor in the detection element collects data on pressure or flow rate during testing of the pipeline and transmits it to the control panel by way of a signal wire. A detection element consists of sensitive and precisely calibrated electrical components which vary depending on manufacturer and leak detection mechanism. These components are enclosed in a durable and corrosion resistant housing. To ensure safety, all electronics contained in the detection element are designed to operate in a highly flammable environment.



Figure 12 - An Example of an ELLD Detection Element and Control Panel

Control Panel

The control panel is the UST operator's interface with the ELLD. It interprets data collected by the detection element to determine pipeline integrity, and communicates the findings to a tank operator or inspector through a visual display or printout. The control panel also allows a tank operator or inspector to conduct random leak tests and program regular periodic tests of the pipeline. Control panels are typically located in an office, on a dispenser, or at some other central location depending on the operator's needs and site installation restrictions. Basic control panels interface with a single detection element and monitor only one pipeline, while more advanced control panels can interface with multiple detection elements and monitor several pipelines. Some control panels also include a printer that generates hard copies of test data (see Figure 13) and a telephone device that can alert off-site personnel if there is a leak. Features of the control panel's display vary by manufacturer and model. See Table 1 for a description of some commonly available features.

```

OCT 19, 1999 1:55 PM
P 1:UNLEADED REGULAR
TEST TYPE = 3.0 GAL/HR
  LINE TESTS
    PREV 24 HOURS = 0
    SINCE MIDNIGHT = 4
  SELF TESTS
    PREV 24 HOURS = 0
    SINCE MIDNIGHT = 1

TEST TYPE = 0.2 GAL/HR
OCT 5, 1999 11:41 PM
PASSED

TEST TYPE = 0.1 GAL/HR
NO 0.1 TEST AVAILABLE

P 2:UNLEADED SUPER
TEST TYPE = 3.0 GAL/HR
  LINE TESTS
    PREV 24 HOURS = 0
    SINCE MIDNIGHT = 3
  SELF TESTS
    PREV 24 HOURS = 0
    SINCE MIDNIGHT = 2

TEST TYPE = 0.2 GAL/HR
NO 0.2 TEST AVAILABLE

TEST TYPE = 0.1 GAL/HR
NO 0.1 TEST AVAILABLE
    
```

Figure 13 - Sample ELLD Printout

See Section 3.5 for information on ELLDs that do not require signal wires.



Figure 14 - An Example of an ELLD Control Panel

TABLE 1 - COMMON ELLD CONTROL PANEL INDICATORS

ELLD Indication	Description
<i>Leak Test Fail</i>	The ELLD detected a leak exceeding the preset threshold during the last piping test.
<i>Leak Test In Progress</i>	The ELLD is currently testing the pipeline for leaks.
<i>High / Low Pressure</i>	The ELLD is detecting abnormally high or low line pressure.
<i>Visual And / Or Audible Alarm</i>	Blinking lights or audible buzzer triggered by an ELLD in the event of a failed leak test in order to notify tank operator of a leak.
<i>Pump Shut Off</i>	ELLD has shut off the pump due to a failed leak check or tamper condition.
<i>Status Indicator</i>	This displays results of the ELLD's continuing self-tests.
<i>Test Log</i>	A printed report of testing times and results that can be reviewed by a tank operator or inspector.
<i>Leak Simulation</i>	This feature allows a tank operator or inspector to test the ELLD's response to a leak (alarms, pump shutdown, etc.).
<i>Reset Switch</i>	This feature allows a tank operator to restart a pump that has been shut off by an ELLD. Various security features can be used with this switch to prevent continued use of a leaking pipeline.

3.3 ELLDs AND AUTOMATIC TANK GAUGING SYSTEMS

As a growing number of UST operators automate their systems, ELLD manufacturers continue to improve the ease and efficiency of interfacing with control panels. Many manufacturers have integrated ELLD control panels into Automatic Tank Gauge (ATG) controls or even personal computers, thereby allowing tank operators to retrieve information and control testing for their entire UST system from a single location. For more information on ATG systems, consult the SWRCB handbook "Understanding Automatic Tank Gauge Systems."

3.4 LEAK DETECTION MECHANISMS

There are three leak detection mechanisms used by most ELLD manufacturers to detect the presence of a leak in the pipeline. The “Pressure Decay” method monitors changes of pressure in the piping over time. The “Volume Displacement” method measures the amount of product required to restore the piping to the initial pressure at the start of the test. The “Constant Pressure” method monitors product flow into the piping during the test period. Each manufacturer uses one of the three listed methods, although they vary in how interferences are dealt with. See Section 3.6 for more information on interferences. More detailed information on these ELLD detection mechanisms are discussed in the following sections.

3.4.1 Pressure Decay ELLDs

Pressure decay ELLDs measure the variation of pressure in the product line over time. Initially, the submersible pump pressurizes the product line when the customer turns on the dispenser. After the customer has finished dispensing the product, turned off the dispenser, and hung up the nozzle, the pump shuts off but pressure is maintained in the piping by a check valve. The test period begins very soon after the pump is shut off. During the test the pressure decay ELLD monitors changes in pressure over a preset period of time. Ideally the pipeline should be able to hold a constant pressure. Any leak in the piping will allow product to escape during the test period, causing the pressure to decay. If the pressure goes below the manufacturer’s set limits within a set time period, the system declares a leak. When installed and programmed properly, the ELLD will shut off the pump and/or trigger audible and visual alarms to notify the operator.

3.4.2 Volume Displacement ELLDs

The volume displacement method measures the amount of product injected into the pipeline to replace product lost during the test period. Initially the submersible pump pressurizes the product line when the customer turns on the dispenser. After the customer has finished dispensing the product, turned off the dispenser and hung up the nozzle, the pump shuts off but pressure is maintained in the piping. The line is left inactive for a preset time period. Ideally, in a “passed” test the pipeline should hold the entire volume of product it contains for the duration of the test. A leaking pipeline will lose product during the test period. At the end of the preset time period of pipeline inactivity, the pump is turned “on” and enough product to restore the pipeline to the initial pressure at the start of the test period is injected into the pipeline. The volume displacement ELLD carefully measures the volume of product injected. A tight pipeline will require little or no injected product, as no product will have escaped. If the volume injected exceeds the manufacturer’s threshold, the system declares a “failed” test. When installed and programmed properly, the ELLD will shut off the pump and/or trigger audible and visual alarms to notify the operator.

3.4.3 Constant Pressure ELLDs

The constant pressure method is similar to the volume displacement method in many ways. Both methods measure the volume of product injected into a pipeline to replace the product lost through a leak. Both require that the volume measured must not exceed a pre-determined limit or the ELLD will declare a leak. The primary difference is that, unlike volume displacement ELLDs, constant pressure ELLDs maintain a constant line pressure throughout the test period by having the pump run continuously. Having the line under constant pressure throughout the test can be helpful in minimizing several potential interferences to accurate line testing, such as pipeline compressibility, trapped vapor, and leaking check valves.

Initially the submersible pump pressurizes the product line when the customer turns "on" the dispenser. After the customer has finished dispensing the product, turned "off" the dispenser, and hung up the nozzle, the pump continues to run and a valve is closed in the piping near the pump outlet (see Figure 15). However, a small passageway between the pump side of the piping and the dispenser side of the piping remains open during the test period. This passageway allows product to flow into the pipeline and replace any product lost due to leaks. The constant pressure ELLD includes a sensitive flow meter that measures the volume of product flowing through this passageway during the test. If the volume exceeds the manufacturer's threshold the system declares a "failed" test. When installed and programmed properly, the ELLD will shut off the pump and/or trigger audible and visual alarms to notify the operator.

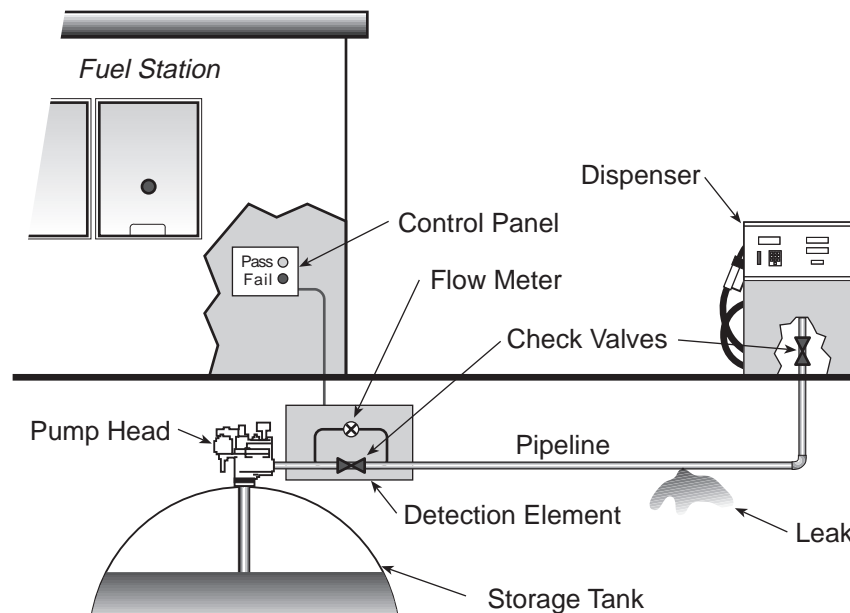

Figure 15 - Constant Pressure ELLD System

3.5 WIRELESS ELLD SYSTEMS

Some ELLD sensors do not require separate wiring to communicate with the control panel. These are known as “wireless” ELLDs. In reality, they are not truly wireless. They rely on pump power wires already installed in the sump to supply power. These same wires are also used to transmit data between the sensor and control panel.

Wireless ELLDs offer a simple and cost-effective solution for upgrading pipeline leak detection at existing UST facilities. They operate on the same leak detection principles and with the same control panel interface as standard ELLDs. Like most ELLDs, the sensor typically fits into a threaded leak detector port on the pump. They require no additional wiring or buried conduit, which means no excavation. This greatly reduces the cost and time of installation. However, there are drawbacks to wireless ELLDs. They are more expensive than a comparable standard ELLD (although this cost is typically more than offset in installation savings on existing UST systems). Additionally, wireless ELLDs are susceptible to certain electrical interferences in the signal between the sensor and the control panel. This interference may come from surrounding electronic devices like fluorescent canopy lighting or variable speed product pumps. However, ELLD manufacturers are constantly improving their products to minimize such interference.

3.6 INTERFERENCE TO THE LEAK DETECTION MECHANISM

As the technology associated with ELLDs continues to evolve, the reliability of devices increases. However, various factors can interfere with accurate testing by the ELLD. This is particularly true when performing the more precise 0.1 gph and 0.2 gph tests. Small interferences in these precise tests can mask leaks that over time can cause major contamination. It is equally possible to declare a “failed” test when there is no flaw in the pipeline. These false alarms can be particularly frustrating for the station operator, since each alarm must be investigated as though an actual leak has occurred. Not all the interferences listed and described in the following paragraphs will pertain to every ELLD. Many ELLDs are designed to operate effectively in spite of some of these potential interferences. Manufacturers or authorized retailers should be consulted for information pertaining to a specific ELLD.

Thermal Contraction

Problem	Solution
<p>As product in a line cools, it will tend to contract. This reduces the overall volume of product in the line although nothing has been released to the environment. An ELLD may interpret this reduction in volume as a loss of product and report a leak where there is none. Thermal contraction most often occurs in mountain or desert locations where there is a significant change in daytime highs and nighttime lows. In some instances thermal contraction may occur when a delivery of warm product is placed into the system and begins to cool.</p>	<p>The impact of thermal contraction varies depending on the specific ELLD used for testing. Many ELLDs are designed to repeat tests when they suspect data has been affected by thermal contraction. Most devices minimize the effects of thermal contraction by allowing the temperature of the product in the pipeline to stabilize before beginning a 0.1 gph or 0.2 gph test.</p>

Thermal Expansion

Problem	Solution
<p>As product in a line warms, it tends to expand. This increases the overall displacement of product in the line, although the actual amount of product may remain constant. If a pipeline has a small leak, the increased displacement due to thermal expansion may offset the loss of product due to leakage. Consequently, an ELLD may miss a small leak. Thermal expansion most often occurs in desert locations where there is a significant change in daytime highs and nighttime lows. In some instances thermal expansion may occur when a delivery of cold product is placed into the system and begins warming to the surrounding temperature.</p>	<p>After 9/22/91 EPA required LLD manufacturers to address this problem and design LLDs that compensate for thermal expansion of approximately 25°F product to ground temperature difference. Manufacturers address this issue when designing their products, and most modern LLDs (particularly those that have been third party certified) are rarely affected by thermal expansion. See the manufacturer’s operations manual for specific instruction on identifying and alleviating thermal expansion.</p>

Trapped Vapor

Problem	Solution
<p>Even a small amount of vapor in a pipeline may cause a test to be inaccurate. When vapor is pressurized, it contracts far more than liquid fuel. This contraction can be interpreted by the ELLD as a loss of product due to leakage, even when no leak is present. Test methods that require pipeline pressure/volume measurements can not be done accurately with vapor in the line. Vapor also compounds the problems associated with thermal contraction.</p>	<p>While many ELLDs may not perform reliable tests with vapor in the lines, they are often capable of detecting its presence. A tank operator may be notified of the presence of vapor in the line through the control panel. The line must be manually purged of all vapor before it can be tested. Some constant pressure method ELLDs are not affected by vapor.</p>

Pipeline Compressibility

Problem	Solution
<p>Many ELLDs use the UST's pump to fill the pipeline with product at high pressure. This can cause a slight expansion of the pipe over the duration of the leak test. This expansion can result in a pressure decrease, which the ELLD may falsely indicate as a leak.</p>	<p>Use only ELLDs that have been third-party certified for use on the type of piping found in that specific UST system. Some ELLDs include calibration to account for a particular pipeline's compressibility.</p>

Tampering

Problem	Solution
<p>An ELLD can not function properly if it has been disconnected, modified, or otherwise tampered with. When an ELLD detects a leak and shuts down a pump or activates an alarm, it is the responsibility of the tank operator to investigate the possible leak. However, it is often easier in the short term for a tank operator to disconnect the ELLD or repeatedly override the alarms, thus prohibiting its continued operation.</p>	<p>Many ELLDs can detect tampering and discontinue use of the pipeline until the tamper condition is cleared. Local authorities often require periodic inspection of LLDs to ensure their proper use. Ultimately it is the responsibility of tank operators to ensure that their ELLDs are in good working order and have not been tampered with.</p>

Check Valves

Problem	Solution
<p>Some ELLDs use a check valve to seal off a pressurized pipe. Once the valve is sealed, the ELLD will monitor the pressure/volume in the line. Debris in the product can cause a check valve to leak (see Figure 16). A leaking check valve allows product to flow from the pipe being tested to the storage tank. This causes a drop in line pressure/volume that the ELLD can interpret as a leak.</p>	<p>Some systems provide an external check valve with an external filter to reduce debris. This extra valve and filter will require scheduled maintenance and cause greater restriction to product flow. Constant pressure ELLDs no longer require the check valve to seal for accurate testing.</p>

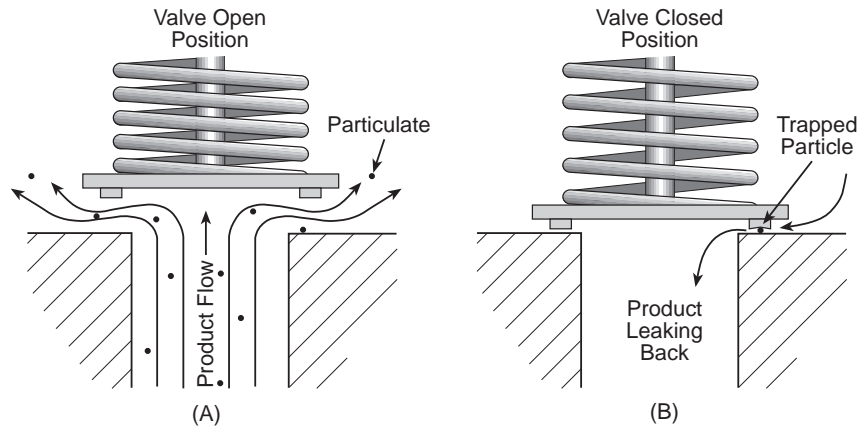

Figure 16 - Diagram of a Leaking Check Valve

3.7 INSTALLATION OVERVIEW

There are several steps to follow when installing an ELLD. The following list covers the major steps required for installation of a “typical” ELLD system. ELLDs can vary in installation requirements, and should always be installed by a qualified professional to ensure safe and proper operation.

- 1. Installation of the ELLD sensor** - The sensor is usually installed inside the pump sump, at the outlet of the pump head. It may be screwed directly into the MLLD port on the pump if compatible (as in Figure 17). This is the simplest and most common option. The sensor may also be installed by use of a specialized LLD “T” in the piping (as in Figure 18), or special sensors with built-in flanges can be installed in line with existing piping.



Figure 17 - ELLD Installed in MLLD Port

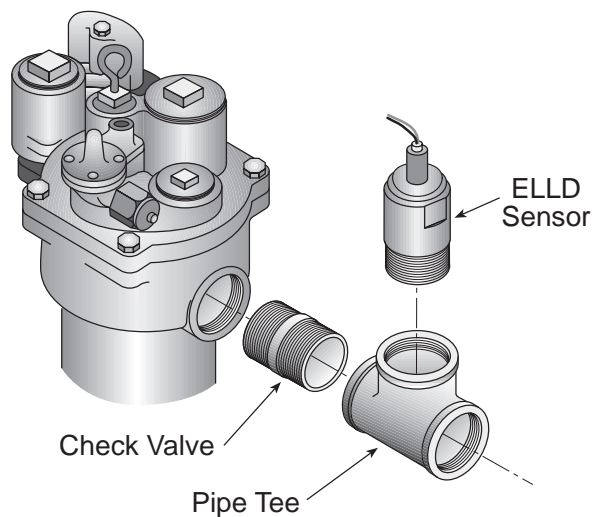

Figure 18 - ELLD Installed in Product Line Using “T” Fitting

- 2. ELLD Wiring** - The ELLD must be wired according to its specific instructions. This may include power to the sensor, communication wires to the control panel, and wiring to disable pump power when leak tests fail. New underground conduit may be required. All wiring must comply with applicable safety standards for use in explosive environments.
- 3. Installation of the Control Panel** - The control panel is generally mounted using a template provided by the manufacturer. When selecting an appropriate location for the control panel, wiring length and routing must be considered. Local agency approval of the control panel location may be required.

- 4. Auxiliary Devices** - Any auxiliary devices must be properly wired to the ELLD. This may include the pump shutdown relay, solenoid operated valves used to isolate the pipe during testing, remote alarms, and communication lines to an Automatic Tank Gauge control panel.
- 5. Calibration** - Many ELLDs require calibration to accurately monitor a specific pipeline. Factors such as pipeline length, diameter, material, and type of product may need to be incorporated. Incorrect calibration can lead to inaccurate testing.
- 6. Testing** - The final step in the installation of an ELLD is testing its effectiveness. This is best done by simulating a leak while the ELLD is testing the pipeline. The contractor should check that the ELLD detects the leak, activates alarms, and shuts down the pump if applicable.

3.8 MAINTENANCE OF THE ELLD

Due to the complexity of ELLDs, only experienced professionals should service them. The basic electronic components, communication functions, and auxiliary alarm device functions may be verified by a series of steps that are pre-programmed into the control panel. These diagnostic and/or functional tests are run automatically by the ELLD or can be initiated by the inspector or tank owner/operator. Refer to the operations manual for instructions that are specific for the model of ELLD used at each facility.

To assist inspectors and tank owners with their review of annual monitoring equipment certification results, a Line Leak Detector System Certification form is provided in Appendix A. The checklist was compiled based on a review of manufacturer requirements and contains a list of minimum procedures service personnel should perform during the annual certification. However, service personnel must follow manufacturers' instructions to perform the maintenance and any specific calibration procedures. It is recommended that a copy of the form be provided to the tank owner.

*California Code of Regulations Title 23 Division 3,
Chapter 16 requires annual certification of LLDs.
California UST Regulations can be found at:
<http://www.swrcb.ca.gov/cwphome/ust>*

3.9 INSPECTION OF THE ELLD

ELLDs should be inspected periodically according to local regulations and manufacturer's guidelines. The compliance inspection should at a minimum include the following:

- Verify that the ELLD is listed in the current version of California's List of Leak Detection Equipment and Methods for Underground Storage Tanks.* (See Appendix C for further information on this list.)
- Verify that the piping specifications are consistent with the third-party certified specifications for the ELLD in use (material, diameter, and overall volume of piping).
- Confirm that the equipment installed at the facility is the equipment specified in the written monitoring program.
- Check the operator's knowledge and familiarity with the system.
- Verify that the operator is familiar with the proper responses to ELLD leak or malfunction indication.
- Check if equipment manuals are available (preferably on-site).
- Review printed test reports and/or alarm histories when available.
- Review annual equipment certification reports.
- Refer to third-party certifications (see California's List of Leak Detection Equipment and Methods for Underground Storage Tanks) to verify system capabilities and confirm that the ELLD is performing tests for which it is certified. For example: Is the tank owner claiming to do annual tightness testing (0.1 gph) with an ELLD that is only certified to perform monthly tightness testing (0.2 gph)?

* This document is referred to as LG-113 and is on the SWRCB website at <http://www.swrcb.ca.gov/cwphome/ust> (See Appendix C for further information.)

Appendix A

Inspection and Maintenance Checklists

Mechanical Line Leak Detector Inspection Checklist			
<i>(For Inspectors and Tank Owners)</i>			
A "No" answer indicates that follow up action is necessary			
Identification of System			
Manufacturer, name, and model of the MLLD unit or system:			
Line leak detector is the same model listed in the monitoring plan?	Yes	No	
Line leak detector is listed in LG-113?	Yes	No	
MLLD unit or system is certified for use with the type of piping present?	Yes	No	
MLLD unit or system is certified for use with the volume of the piping present?	Yes	No	
Operation/maintenance manual is available?	Yes	No	
Equipment Check			
Pump Sump is free from any leak or contamination?	Yes	No	
If no, has it been documented?	Yes	No	
Vent tube is free from leaks or any kinks that may obstruct product flow? (if applicable)	Yes	No	
UST system is free of continuously running pumps or dispensers left in the on position to cause continuous pump run?	Yes	No	
The system is free from tampering in the sump areas?	Yes	No	
Reviewing the records			
Documentation is available showing the system was installed, calibrated, and maintained in accordance with manufacturer's instructions, including routine maintenance and service checks at least once per calendar year?	Yes	No	
	Date: _____		
The Annual Equipment Certification Report is available and has been reviewed?	Yes	No	NA
Maintenance and test records are available for the last 3 years (or the life of the tank if less than 3 years old)?	Yes	No	
There is documentation to show that failed tests were recorded and/or reported to the local agency? (if applicable)	Yes	No	
The annual equipment certification was done on-line, without removal from the system?	Yes	No	
The mechanical line leak detector was quantitatively tested and was able to detect a simulated leak rate of 3 gph?	Yes	No	

Comments:-

Inspector's Signature and Date: _____ Reinspection Date: _____

Electronic Line Leak Detector Inspection Checklist		
<i>(For Inspectors and Tank Owners)</i>		
A "No" answer indicates that follow up action is necessary		
Identification of System		
Manufacturer, name, and model of the ELLD unit or system:		
The line leak detector is the same model listed in the monitoring plan?	Yes	No
The line leak detector is listed in LG-113?	Yes	No
The ELLD unit or system is certified for use with the type of piping present?	Yes	No
The ELLD unit or system is certified for use with the volume of the piping present?	Yes	No
There is NO MLLD installed in the system? (This may interfere with operation of the ELLD.	Yes	No
There is an operation/maintenance manual available?	Yes	No
Equipment Check		
Is the system power indicator on?	Yes	No
There are no alarm conditions indicated?	Yes	No
The system prints hard copies of test reports if applicable?	Yes	No
The pump sump is free of any leaks or contamination?	Yes	No
If no, has it been documented?	Yes	No
The pump automatically shuts off if the ELLD detects a leak?	Yes	No
The pump automatically shuts off if any component of the line leak detector malfunctions or fails a diagnostic test? *	Yes	No
The pump automatically shuts off if any component of the line leak detector is disconnected or disabled? *	Yes	No
The line leak detector is installed to prevent unauthorized tampering?	Yes	No
Reviewing the records		
Documentation is available showing the system was installed, calibrated, and maintained in accordance with manufacturer's instructions, including routine maintenance and service checks at least once per calendar year?	Yes	No
	Date: _____	
The Annual Equipment Certification Report is available and has been reviewed?	Yes	No
Maintenance and test records are available for the last 3 years (or the life of the tank if less than 3 years old)?	Yes	No
There is documentation to show that failed tests were recorded and/or reported to the local agency? (if applicable)	Yes	No
The line leak detector is specified by the monitoring plan to perform a 0.2 gph monthly test?	Yes	No
The line leak detector is specified by the monitoring plan to perform a 0.1 gph annual test?	Yes	No
If yes, inspect documentation and review results.		
If not, when was the last tightness test conducted?		

*Required after 12/22/98 for all leak detection systems installed in single-walled pressurized piping systems. These checks are often done with maintenance personnel present, or by reviewing the records of the most recent annual equipment certification.

Inspector's Signature and Date: _____ Reinspection Date: _____

LINE LEAK DETECTOR (LLD) SYSTEM CERTIFICATION

This form is a portion of a UST monitoring system certification form currently under development in the State of California. Only sections relevant to LLDs are included in this version. For a complete UST certification form, check the SWRCB website at <http://www.swrcb.ca.gov>

A. General Information

Facility Name: _____ Bldg. No.: _____

Site Address: _____ City: _____ Zip: _____

Facility Contact Person: _____ Contact Phone No.: _____

Make/Model of LLD System: _____ Date of Testing/Servicing: ___/___/___

B. Line Leak Detectors (LLD): Check this box if LLDs are not installed.

Complete the following checklist: Software version installed: _____

Yes	No*	NA	For equipment start-up or annual equipment certification, was a leak simulated to verify LLD performance? (Circle all that apply) Simulated leak rate: 3 gph 0.1 gph 0.2 gph
Yes	No*		Is the audible alarm operational?
Yes	No*		Is the visual alarm operational?
Yes	No*	NA	If alarms are relayed to a remote monitoring station, is all communications equipment (e.g. modem) operational?
Yes	No*		Was monitoring system set-up reviewed to ensure proper settings?
Yes	No*		Was the testing apparatus properly calibrated?
Yes	No*	NA	For mechanical LLDs, does the LLD restrict product flow if it detects a leak?
Yes	No*	NA	For electronic LLDs, have all accessible wiring connections been visually inspected?
Yes	No*	NA	For electronic LLDs, does the turbine automatically shut off if the LLD detects a leak?
Yes	No*	NA	For electronic LLDs, does the turbine automatically shut off if any portion of the monitoring system is disabled or disconnected?
Yes	No*	NA	For electronic LLDs, does the turbine automatically shut off if any portion of the monitoring system malfunctions or fails a test?
Yes	No*		Were all items on the equipment manufacturer's maintenance checklist completed?
Yes	No*		Were all LLDs confirmed operational and accurate within regulatory requirements?

* In the Section D, describe how and when these deficiencies were or will be corrected.

C. Certification - I certify that the equipment identified in this document was inspected/ serviced in accordance with the manufacturer's guidelines. Attached to this Certification is information (e.g. manufacturer's checklists) necessary to verify that this information is correct. For any equipment capable of generating such reports, I have also attached a copy of the (check all that apply): System set-up report Alarm history report

Technician Name (print): _____ Cert./Lic. No. _____ Signature: _____

Testing Company Name: _____ Phone No.: (____) _____

D. Comments: _____

General Instructions

1. Equipment that monitors underground storage tank systems containing hazardous materials must be tested/serviced annually, or on a schedule specified by the manufacturer, whichever is more frequent.
2. Except in the case of emergency repairs, many local agencies require that a permit be obtained prior to installing new monitoring systems or components (i.e. installation of new or different equipment, rather than using parts identical to those replaced). Check with your local agency for their requirements before starting work.

Section B Instructions

1. Line leak detectors should be tested in-place, not removed.
2. The functional elements of the mechanical LLD are the piston and diaphragm. To ensure that these functional elements are functioning properly, the submersible pump can be started and the time that the piston or diaphragm takes to move into a position to allow full flow of the product noted. The range of allowable opening times is specified by the manufacturer and is available in the equipment manual.
3. **System Set-Up Report** – If the monitoring system or diagnostic equipment used in testing is capable of generating a hard-copy report describing system set-up, you must include a copy of the report with this certification.
4. **Alarm History Report** – If the monitoring system is capable of generating a hard-copy alarm history report, you must include a copy of the report with this certification. This report should be printed before and after testing the system.

Section C Instructions

1. Certification must be made by a licensed and certified technician as per California's Health and Safety Code, Chapter 6.7, 25284.1(a)(5)(D)
2. All work associated with testing/servicing of equipment must be performed by or under the direct supervision of the certifying technician.

Appendix B

Regulatory Requirements

Monitoring Requirements for Single-Walled Piping Systems	
<p>Pressurized Piping</p>	<p>Use an automatic line leak detector that</p> <ul style="list-style-type: none"> • detects a release equivalent to 3.0 gph defined at 10 psi and • shuts off product flow and triggers an audible and visual alarm if a release is detected. (For emergency generator systems, the line leak detector may instead be connected to an audible and visible alarm.) <p>Also monitor the piping with either of the following</p> <ul style="list-style-type: none"> • a monthly piping test that is third-party certified to detect a release equivalent to 0.2 gph defined at normal operating pressure <li style="text-align: center;">or • an annual piping integrity test that is third-party certified to detect a release equivalent to 0.1 gph defined at 150% of normal operating pressure.
<p>Conventional Suction Piping <i>foot or angle check valve is installed below grade</i></p>	<p>Monitor the piping with</p> <ul style="list-style-type: none"> • a piping test once every three years using a method that is third-party certified either <ul style="list-style-type: none"> • to detect a release equivalent to 0.1 gph defined at a minimum of 40 psi • or, if the piping cannot be isolated from the tank, another test method approved by the local agency, for example, an overfilled volumetric tank integrity test. • daily visual monitoring (see Appendix II, CCR). For emergency generator systems, visual monitoring is required at least monthly.
<p>Safe Suction Piping <i>Piping slopes back to the tank, valves and pumps are installed above grade, and only one check valve is installed which is located below and near the suction pump</i></p>	<ul style="list-style-type: none"> • All required “safe suction” design elements must be verifiable. • No monitoring of the suction piping from the tank to the pump is required. • Daily visual monitoring of the pump system is required (see Appendix II, Title 23). For emergency generator systems, visual monitoring is required at least monthly.
<p>Sloped Gravity Lines <i>Sloped less than 90° e.g., a remote gravity fill on a petroleum UST</i></p>	<p>Monitor the piping with a piping integrity test once every two years using a method that is third-party certified</p> <ul style="list-style-type: none"> • to detect a release equivalent to 0.1 gph defined at a minimum of 40 psi <li style="text-align: center;">or • if the piping cannot be isolated from the tank, another test method approved by the local agency, for example, an overfilled volumetric tank integrity test.
<p>Vent Lines, Vapor Recovery Lines, and Fill Risers</p>	<p>This category is exempt from the definition of piping if it has been designed to prevent and does not hold standing fluid in the pipes. See Title 23 and Section 25281.5 in Chapter 6.7 of the California Health and Safety Code for details.</p> <p>If the piping is not exempt, the same monitoring requirements apply as for sloped gravity lines.</p>

Monitoring Requirements for Double-Walled Piping Systems	
<p>Pressurized Piping - <i>Option 1</i></p>	<p>Continuous monitoring system that</p> <ul style="list-style-type: none"> • monitors the secondary containment system and • activates an audible and visual alarm system when a release condition is detected. <p>Automatic Line Leak Detector that</p> <ul style="list-style-type: none"> • detects a release equivalent to 3.0 gph defined at 10 psi. <p>Piping Integrity Test that</p> <ul style="list-style-type: none"> • detects a release from the primary piping equivalent to 0.1 gph defined at 150% of normal operating pressure.
<p>Pressurized Piping - <i>Option 2</i></p>	<p>Continuous monitoring system that</p> <ul style="list-style-type: none"> • monitors the secondary containment system; • activates an audible and visual alarm system when a release condition is detected; and • shuts down the pump system when a release condition is detected. <p>Piping Integrity Test that</p> <ul style="list-style-type: none"> • detects a release from the primary piping equivalent to 0.1 gph defined at 150% of normal operating pressure.
<p>Pressurized Piping - <i>Option 3</i></p>	<p>Continuous monitoring system that</p> <ul style="list-style-type: none"> • monitors the secondary containment system; • activates an audible and visual alarm system when a release condition is detected; • shuts down the pump system when a release condition is detected; and • shuts down the pumping system if the continuous monitoring system fails or is disconnected.
<p>Pressurized Piping - <i>For Emergency Generators Only</i></p>	<p>Continuous monitoring system that</p> <ul style="list-style-type: none"> • monitors the secondary containment system and • activates an audible and visual alarm system when a release condition is detected. (Pump shutdown is not required.) <p>Automatic Line Leak Detector that</p> <ul style="list-style-type: none"> • detects a release equivalent to 3.0 gph defined at 10 psi. (Pump shutdown is not required.)
<p>Conventional Suction Piping, Sloped Gravity Lines, Non-exempt Vent Lines, Vapor Recovery Lines, and Fill Risers</p>	<p>Continuous monitoring system that</p> <ul style="list-style-type: none"> • monitors the secondary containment system and • activates an audible and visual alarm system when a release condition is detected.

Appendix C

Third-Party Certification of Line Leak Detectors

THIRD-PARTY CERTIFICATION

To protect the tank owners against the conflicting claims of manufacturers, the possibility of environmental damage, and the threat to human health and safety, California and Federal regulations require that all leak detectors be evaluated using a comprehensive testing procedure. This procedure determines how accurate a LLD is, and what types of products and piping it can be used with. The evaluation is performed by an independent third party organization. Independent third parties may include consulting firms, test laboratories, not-for-profit research organizations, or educational institutions with no organizational conflict of interest. The results of the evaluation are reviewed by members of a national workgroup on leak detection evaluation and SWRCB, then summarized and published in a National List and California's LG-113 for use by UST owners and inspectors.

Conducting the Evaluation

The EPA has established guidelines that describe how equipment should be evaluated. The guidelines are flexible enough to allow for a variety of approaches and accommodate a variety of LLDs, but specific enough to be verifiable and repeatable. They require a leak detection system to be evaluated under a wide range of pipeline configurations and test conditions. The basic steps in the EPA evaluation protocol are outlined below to provide a general understanding of the process.

1. **Describe the leak detection system** - a detailed description of the system being evaluated.
2. **Select an evaluation option** - a leak detection system can be evaluated at a special test facility, an operational UST with special monitoring equipment, several operational USTs without special monitoring equipment, or by using a validated computer simulation.
3. **Select temperature and leak conditions** - the leak detection system must be evaluated at a variety of leak rates and temperatures to ensure accuracy in the field.
4. **Assemble equipment and diagnostic instrumentation** - all test equipment and measuring devices must be calibrated to the accuracy specified in the EPA protocol.
5. **Verify the integrity of the pipeline system** - a leak detection system should be evaluated on a non-leaking pipeline, where specific leak rates can be simulated.
6. **Determine the characteristics of the pipeline system** - the pipeline must meet specifications for length, diameter, and compressibility. This will determine for which type of piping the leak detection system will be approved.
7. **Evaluate the performance characteristics of the detection element** - the precision, accuracy, minimum detectable quantity, and what the instrument is measuring (i.e., pressure, volume, or flow rate changes) must be determined.
8. **Develop a relationship between the leak and the output of the measurement system** - this is the relationship between the signal from the leak and the signal from other interferences in the piping systems, such as thermal expansion or pipeline compressibility.

9. **Develop a histogram of the noise** - this is done using data collected at a variety of temperatures (typically 25 tests, as specified in the evaluation protocol), and will be used to determine the probability of false alarm (PFA) of the leak detection system.
10. **Develop a histogram of the signal-plus-noise** - consisting of data collected as in step 9, this histogram is used to determine the probability of detection (PD) of a leak detection system.
11. **Determine the system's sensitivity to trapped vapor** - the protocol outlines three special tests to accomplish this.
12. **Conduct the performance analysis** - analyze the data collected to determine PFA and PD at the EPA specified leak rate. This will determine if the leak detection system is suitable for use in 0.1 gph, 0.2 gph, or 3 gph testing.
13. **Evaluation report** - the evaluation report is done in a standard format, and contains all information regarding the evaluation, including testing procedure, conditions, and results.

Leak Detection Equipment List

SWRCB publishes a comprehensive list of third-party certified leak detection equipment known as LG 113. It contains certification information on each currently approved leak detection product. A sample LG 113 page is included below with brief explanations of the included information.

Make and model of the LLD. Be sure to match this exactly with the LLD in question.

Check the date and always use the current edition

Leak detection equipment category. LG 113 covers LLDs and a variety of other UST leak detection methods.

California Edition: June 1999

Leak Pro Manufacturing
LPM 4000, LPM 9000, LM 1401, LM 1801
(for flexible pipelines)

AUTOMATIC ELECTRONIC LINE LEAK DETECTOR

Certification: Leak rate of 0.2 gph with $P_D = 100\%$ and $P_{FA} = 0\%$.

Leak Threshold: 0.1 gph. A pipeline system should not be declared tight if the test result indicates a loss that equals or exceeds this threshold.

Applicability: Gasoline, diesel, aviation fuel, solvents, methanol, ethanol, gasoline blends with methanol and ethanol.

Specification: System tests pressurized flexible pipelines. Tests are conducted at 10 to 12 psi.

Pipeline Capacity: Maximum of 27.6 gallons.

Waiting Time: None between delivery and testing.
None between dispensing and testing.

Test Period: Response time is 9 minutes to 2 hours, 30 minutes.
Test data are acquired and recorded by a microprocessor.
Calculations are automatically performed by the microprocessor

System Features: Permanent installation on pipeline.
Automatic testing of pipeline.
Preset threshold.
Single test to determine if pipeline is leaking.
Recording and display of day, date, and time of conclusive test.
Pump shutdown, message display, and alarm activation if leak is declared.

Calibration: System must be checked annually and calibrated if necessary in accordance with manufacturer's instructions.

Comments: LPM 4000 is a stand alone automatic electronic line leak detector.
LPM 9000 is a combination of LPM 5000 automatic tank gauge and LPM 4000 automatic electronic line leak detector.
LP 1401L is a combination of ST 1400 automatic tank gauge and ST 1401L automatic electronic line leak detector.
LP 1801L is a combination LP1800 automatic tank gauge and LP 1801L automatic electronic line leak detector.

Leak Pro Manufacturing, Inc.
1234 Main St.
Sacramento, CA 75006
Tel: (800) 555-2526

Evaluator: ACME Labs
Tel: (816) 555-2494

Date of Evaluation: 02/02/93

Manufacturer's contact information

Evaluator's contact information

The leak rate that the unit is certified to detect

Products that the LLD is certified for use with

The type of piping for which the LLD is certified

Maximum capacity of the pipeline the LLD is certified to test.

Waiting period required before conducting a test

How long the LLD requires to conduct a test

Basic features of the LLD

A brief description of LLD calibration requirements

Additional information an owner or inspector may need about the equipment

Appendix D

References

References

New Technology for Pipeline Leak Detection

Brad T. Fiechtner, Hasstech Inc.

Prepared for the SWRCB UST conference, 9-9-92

Standard Test Procedures for Evaluation Leak Detection Methods: Pipeline Leak Detection Systems

USEPA office of Research and Development

September 1990

Service Station Pipeline Leak Detectors

Nancy D. Wolff, Chevron USA Inc.

Prepared for the SWRCB UST Leak Prevention Seminars, 7-20-88

Understanding Automatic Tank Gauging Systems

State Water Resources Control Board

November 1996

Detecting Leak: Successful Methods Step-by-Step

USEPA

November 1989

Underground Storage Systems – Leak Detection and Monitoring

Todd G. Schwendman and H. Kendall Wilcox

Lewis Publishers, Inc. 1987

Product brochures, operating instructions, installation manuals, internet sites, and maintenance guides from the following manufacturers:

Campo/Miller, Inc.

Emco Electronics, Tuthill Corp

Environ Products, Inc.

FE Petro Inc.

Gillbarco Environmental Products

Hasstech

INCON Intelligent Controls, Inc.

Marley Pump Co.

Petrovend

Ronan Engineering

Smith Fiberglass Products Inc.

Vaporless Manufacturing

Veeder-Root